

THREAD SIZE	C max	D max	INSTAL. TORQUE	RECOM. CLEAR. HOLE (max.)	LENGTH
2-56 UNC-2A	0.168"	0.055"	2.5 inch lbs	0.095"	1/4-5/8" INCL.
3-48 UNC-2A	0.194"	0.063"	3.9 inch lbs	0.113"	1/4-5/8" INCL.
3-56 UNF-2A	0.194"	0.063"	4.4 inch lbs	0.113"	1/4-5/8" INCL.
4-40 UNC-2A	0.220"	0.069"	5.2 inch lbs	0.128"	1/4-1" INCL.
5-40 UNC-2A	0.245"	0.075"	7.7 inch lbs	0.144"	1/4-1" INCL.
6-32 UNC-2A	0.271"	0.083"	9.6 inch lbs	0.149"	1/4-1" INCL.
6-40 UNF-2A	0.271"	0.083"	12.1 inch lbs	0.149"	1/8" INCL.
8-32 UNC-2A	0.323"	0.097"	19.8 inch lbs	0.177"	1/4-1" INCL.
10-24 UNC-2A	0.374"	0.113"	22.8 inch lbs	0.201"	1/4-1" INCL.
10-32 UNF-2A	0.374"	0.113"	31.7 inch lbs	0.201"	1/4-1" INCL.
1/4-20 UNC-2A	0.493"	0.148"	75.2 inch lbs	0.250"	5/16-1 1/4" INCL.
1/4-28 UNF-2A	0.493"	0.148"	94 inch lbs	0.250"	5/16-1 1/4" INCL.

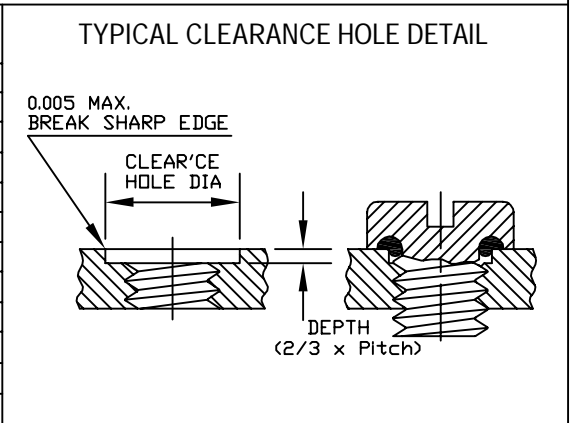

STANDARD SPECIFICATIONS & COMMON OPTIONS (HOW TO ORDER)

STD. SCREW MATERIAL: TYPE 18/8 STAINLESS STEEL PER DFARS (OTHER MATERIALS AVAILABLE)

STD. SCREW FINISH: NATURAL (PASSIVATED QQ-P-35 UNLESS OTHERWISE SPECIFIED)

STD. O-RING MATERIAL: SILICONE RUBBER (SEE TABLE FOR O-RING OPTIONS)

SAMPLE CATALOG NO.		S2-56X1/4-2701-BLKOX
SCREW TYPE	S	PAN HEAD WITH SLOTTED RECESS
THREAD	2-56	ENTER BASIC THREAD SIZE
	X	
LENGTH	1/4	ENTER LENGTH
O-RING SUFFIX	-2701	ENTER FROM TABLE
OPTIONS	-BLKOX	ENTER FROM TABLE

AVAILABLE O-RING MATERIALS		
Compound Suffix	Material	Service Temp.
-2701	Silicone Rubber	-150°F to 500°F -101°C to 260°C
-2615	Fluoro-Silicone Rubber	-78°F to 450°F -61°C to 232°C
-5701	Viton® A	-20°F to 400°F -29°C to 204°C
-4601	Buna N (NBR)	-65°F to 250°F -54°C to 121°C
-3701	Neoprene (EPR)	-65°F to 300°F -54°C to 149°C
-7601	Ethylene Propylene (EPDM)	-65°F to 300°F -54°C to 149°C

COMMON OPTIONS	
SUFFIX	DESCRIPTION
-BLKOX	BLACK OXIDE PER MIL-C-13924A, CLASS 2
-NY	LOCKING NYLON PELLET
-LY	LOCKING NYLON STRIP
-TP	LOCKING NYLON STD. PATCH
-HTP	HIGH TEMP. LOCKING NYLON PATCH

O	ADDED THREAD SIZE 6-40 UNF-2A	S. GOK	07.06.10
N	CHANGED CLEAR. HOLE MAX AND SCREW FINISH, TOOK OFF MIN. AND ADDED INST. TORQUE	S. GOK	04.13.10
M	ADDED "PER DFARS" FOR THE SCREW MATERIAL	S. GOK	07.02.09
L	NEW DRAWING FORMAT	S. GOK	01.21.09
K	CAD COMPUTER GENERATED	S. GOK	09.09.08

REV.	DESCRIPTION	DATE
MAXIMUM AND MINIMUM MEASUREMENTS ARE STATED DIRECTLY ON EACH DIMENSION.		
TITLE: SEELSKREW ®, PAN HEAD SLOTTED		ENG. DWN. S. ANDREWS
MAT'L: AS NOTED		CHKD.
FINISH: AS NOTED		SCALE DWG. NO. S-0000-00-00

THIS DRAWING COVERS PROPRIETARY ITEM AND IS THE PROPERTY OF THE APM-HEXSEAL CORPORATION. THIS DRAWING IS NOT TO BE COPIED OR USED WITHOUT THE WRITTEN APPROVAL OF AN OFFICER OF THE APM-HEXSEAL CORPORATION.